

## **Increasing Effective Region in Magnetorheological Valve using Serpentine Flux Path Method**

\*Abdul Y. Abd Fatah<sup>1)</sup>, Saiful A. Mazlan<sup>2)</sup>,  
Tsuyoshi Koga<sup>3)</sup> and Hairi Zamzuri<sup>4)</sup>

<sup>1), 2)</sup> *Vehicle System Engineering, Malaysia-Japan International Institute of Technology,  
Universiti Teknologi Malaysia, 54100 Kuala Lumpur, Malaysia*

<sup>3)</sup> *Graduate School of Science and Engineering, Department of Mechanical  
Engineering, Faculty of Engineering, Yamaguchi University,  
2-16-1 Tokiwadai Ube-shi, Yamaguchi, 755-8611 Japan*

<sup>4)</sup> *UTM-Proton Active Safety Laboratory, Razak School of Engineering and Advanced  
Technology, Universiti Teknologi Malaysia, 54100 Kuala Lumpur, Malaysia*

<sup>1)</sup> *yasser@ic.utm.my*

### **ABSTRACT**

In order to increase the performance of devices that are using magnetorheological (MR) valve, one of the ways is to increase the effective region within the valve, where the rheological properties of MR fluids are manipulated within this effective region. There are many ways to increase the effective region or activation area in the MR valve, including increasing the dimension, elongating the flow path of the MR fluids in the effective region, or maximizing the magnetic flux path into the said area. This paper discussed about increasing the effective area inside a MR valve by maximizing the flux path into the effective area. This can be done by using serpentine flux path method, where the magnetic flux is weaved into the effective region to increase the magnetic flux into the region. The weaving of magnetic flux can be done by manipulation of magnetic and non-magnetic materials so that the magnetic flux in the valve is bended by these materials to reintroduce the magnetic flux path into the effective region. Works are done in Finite Element Method Magnetics (FEMM) simulation software, where the average magnetic flux density in the effective area can be calculated in Tesla. Initial results acquired in simulation show that by using same number of turn in magnetic coil and same average magnetic flux density in the effective region, the valve with serpentine flux path produces higher pressure drop than in normal valve with same dimension, thus increasing the possibility of achieving higher damping force by using serpentine-flux valve as compared to the normal valve.

---

<sup>1)</sup> Ph.D Student

<sup>2),3) and 4)</sup> Ph.D

Note: Copied from the manuscript submitted to "Smart Structures and Systems, An International Journal" for presentation at ASEM13 Congress.

## 1. INTRODUCTION

Magnetorheological fluid (MRF) has recently caught lots of attentions from researchers especially to those who involved with works and applications of smart materials, which have the ability to change their properties significantly by applying external factors or stimuli. For MRF, the smart material's ability of it is that it can change its rheological properties from Newtonian fluid into a nearly solid-like state with the application of magnetic field (Jolly et al. 1996). MRF is usually categorized in the same group as electrorheological fluid (ERF) and ferrofluids, where they were referred to as controllable fluid since their rheological behavior are varying rapidly with the presence of an external excitation field such as electric and magnetic field (Spencer et al. 1996, Weiss et al. 1994, Yalcintas and Dai 1999). There are four main properties that can be considered as the advantages of using MRF from previous study, as listed below:

- It can change its viscosity into solid-like state and this effect is reversible
- It can react instantaneously in the presence of magnetic field
- It's viscosity's change can be controlled by varying the magnetic field strength, where this can be done by using electromagnetic circuit
- It can produce higher yield stress with lower power consumed as compared to other controllable fluid such as ERF

For its advantages listed above, it is natural for researches involving with application of MRF are usually active in working on devices with the use of controllable damping forces, such as dampers, clutches and brakes. This is evident from previous works, such as works on magnetorheological (MR) dampers from early patent on MR damper (Carlson and Chrzan 1994), phenomenological model of MR dampers (Spencer et al. 1996), MR damper with self-power generation for electromagnetic circuit (Chen and Liao 2012, Choi and Wereley 2009) and large scale MR damper (Sodeyama et al. 2003; Yang et al. 2002); clutches from earliest work on MR clutch (Rabinow 1948) to transmission clutches for automotive (Neelakantan 2005) and comparison between ERF and MRF clutches (Choi et al. 1999); and brakes, which involved works from brakes on cycling and aerobic machine (search Carlson actuator) to cylindrical MRF brake (Huang et al. 2011), compact double-disk MR brake (Zhou et al. 2007) and brake using serpentine flux path (Senkal and Gurocak 2010). Besides the usual usage of MRF in application with controllable damping forces, MRF also has been researched in other field, where advance devices and applications from works on dampers, brakes and clutches are applied in those field, such as haptic devices that using MRF for haptic feedback (Blake and Gurocak 2009, Liu et al. 2006, Sgambelluri et al. 2006), applications in prosthetic limbs (Carlson et al. 2001, Carlson and Sproston 2000) applications in seismic protection (Cho et al. 2005, Dyke et al. 1998) and applications in military such as gun recoil and field artillery (Sassi et al. 2005), helicopter rotor system (Wang et al. 2006) and heavy vehicle seat suspension (Ahmadian et al. 2005, Reichert and Ahmadian 1997, Şahin et al. 2005). Furthermore, there are also works done to expand other usage possibilities of MRF, such as heat and mass transfer from MR effect (Kordonsky et al. 1993) where it can help with heat transfer in devices such as air conditioner and fridge.

Currently, all devices that are using MRF are in form of these modes; 1) valve 2) direct shear and 3) squeeze mode (Carlson and Jolly 2000). The application of valve mode including dampers, shock absorbers and actuators, while in shear mode it is also applied in damping (Wereley et al. 2008) in addition of application in braking, clutching, locking devices and structural composites (Carlson and Jolly 2000). However, very little studies has been done in understanding the behaviour of squeeze mode of MRF devices, even though theoretical studies on dampers have been done to investigate the characteristics of squeeze mode MR damper (Carmignani et al. 2006, Forte et al. 2004). There is another mode that has been in recent discussion of available working MRF devices modes theoretically, the magnetic gradient pinch, where it has the same properties as valve mode but with different magnetic field configuration and might be applicable to devices that require smaller space and involving high force application (Goncalves and Carlson 2009). Studies from Carmignani et al. 2006 shows that MR damper in squeeze mode has been very effective in rotor vibrations damping and dynamic characteristics control by varying the current in magnetic coil, in addition to the advantage of using such devices with relatively low voltages, although a lot of problems such as cavitation and two-dimensional effects are unsolved (Carmignani et al. 2006, Forte et al. 2004). Besides that, other studies for MRF devices in squeeze mode including design of magnetic circuit in squeeze mode (Mazlan et al. 2009), design and evaluation of performance of MRF in dynamic squeeze, shear-flow, and mixed modes (El Wahed and Mcewan 2011), effects of thermal growth on vibration behaviour on rotor system on squeeze mode MRD (Ghaednia and Ohadi 2010), magnetic circuit simulation on MRF testing rig in squeeze mode (Ismail et al. 2010) and compressive and tensile stress of MRF in squeeze mode (Mazlan et al. 2011), among others.

This paper aims to elaborate on design of a magnetorheological valve with flow valve mode that will be used in MR devices. The design is using serpentine flux path method to increase the effective region inside the valve as to increase the amount of pressure drop it can withstand in low velocity movement. For that purpose, this paper is divided into sections, where it will first explains about the MR fluid control valve in general with a little introduction to serpentine flux path, and then it will discuss about the design of valve using serpentine flux path method. Next section will discuss about the FEMM simulation results on the magnetic field strength of effective regions inside the valve, which also resulting in calculation of yield stress, pressure drop and damping force of the valve, and also discussion on the results obtained from the simulations and calculations done. Finally it will ends with conclusion of the works done.

## **2. MAGNETORHEOLOGICAL FLUID CONTROL VALVE**

Control valve is where the MR effect takes place in the MR damper. In the MR control valve, magnetic field is presence and usually it comes from magnetic circuits where the magnetic field intensity and strength can be controlled from current. A typical MR valve has magnetic circuits which comprises of flux ring, which usually known as magnetic housing, magnetic core, bobbin which is used to wind induction coil and the flow channel to allow MR fluid to go through (Fig. 1) (Zhu et al. 2012). Depending on the configurations, the placement of coils and the configuration of the flow channels can be

varied. The material selection also plays an important part, where the magnetic flux can be manipulated and guided inside the valve by proper selection and configuration of the magnetic and non-magnetic materials inside the valve, where the properties of high magnetic permeability and saturation helps to guide the magnetic flux efficiently (Poynor 2001).

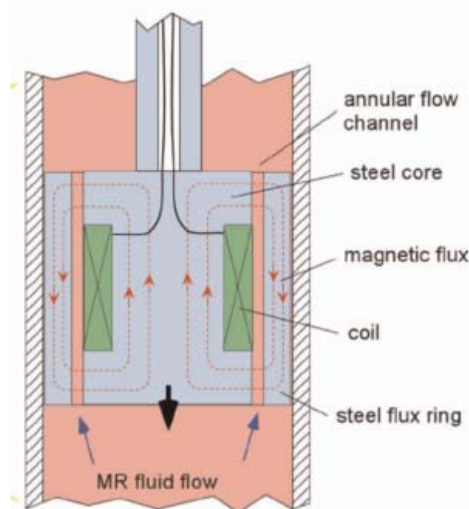

Fig. 1 Typical MR valve (Zhu et al. 2012)

For coil configuration, there are two ways to put the coil inside MR damper so that the magnetic field is present in the control valve. One of them is by putting the coil inside the cylinder, usually by winding up the inductive wire at the piston area so that the piston is becoming a bobbin (Zhu et al. 2012). The remnants of the wire are guided out from MR damper through the piston rod so that it can be connected to the electrical power source for generating magnetic field. This configuration is called internal coil, and the direction of magnetic field is usually perpendicular to the MR fluid flow channel (Zhu, et al. 2012). Whereas for external coil, the inducted wire is used to wrap around the cylinder and the remnants of the wire needed to be connected to the power source are not needed to be put through the piston rod (Zhu et al. 2012). The direction of magnetic field from external coils is parallel to the flow channel inside the valve this poses a problem as the most of MR working mode especially the valve flow and shear mode prefer the magnetic field direction to be perpendicular to the flow channel rather than parallel to the flow channel (Zhu et al. 2012). In addition, more pressure with faster control response and fewer leakages can be obtained by using internal coil rather than using external coil (Unsal and Crane 2006).

In order to configure the coil effectively in the control valve, the flow channel must be configured so that the magnetic flux produced from the coil can be guided into the MR effective intended area, or usually referred to as effective region or effective area, where the dynamic yield stress of the MR fluid in the effective area is increased or

decreased by increasing or decreasing the magnetic field intensity from the magnetic coil. In other words, the damping force can be controlled by controlling the magnetic field intensity from the coil where the damping force is coming from the viscosity of the MR fluid. For this purpose, there are two ways to provide channel for the fluid to flow into the valve: annular gap and radial gap (Fig. 2) (Sahin et al. 2012). Annular gap is the flow channel parallel to the flow path inside the valve and the use of internal coil helps to increase the magnetic flux to be guided into annular gap as the direction of magnetic field is perpendicular to the flow path. Therefore, the electromagnetic coil used for annular gap is wrapped on annulus and is placed within the fluid flow and by doing so, the annular gap will becoming an effective area for MR fluid flows into it (Sahin et al. 2012). To know the pressure drop within the annular gap, calculation for pressure drop in an MR valve needed to be known and the general equation is presented as follows (Nguyen et al. 2009):

$$\Delta P_{valve} = \Delta P_{viscous} + \Delta P_{yield} \quad (1)$$

For annular gap, both  $\Delta P_{viscous}$  and  $\Delta P_{yield}$  are presented as follows (Wang et al. 2009):

$$\Delta P_{viscous} = \frac{6\eta QL}{\pi d^3 R} \quad (2)$$

$$\Delta P_{yield} = \frac{c \tau(B)L}{d} \quad (3)$$

where (d) is the gap of flow channel, ( $\eta$ ) is the fluid base viscosity, (Q) is the flow rate, (L) is the flow channel length, (R) is the channel radius, (c) is flow velocity profile function, and  $\tau(B)$  is the field dependent yield stress, where B is the flux density.

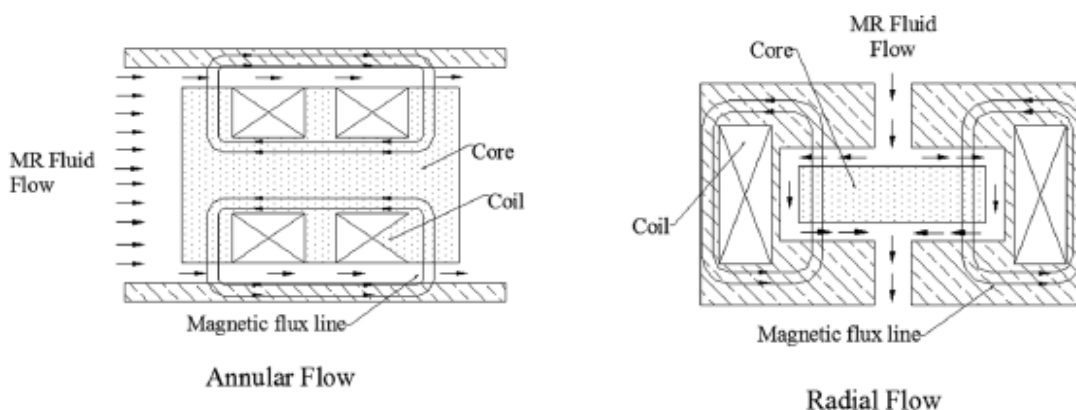

Fig. 2 Annular and Radial Flow (Sahin et al. 2012)

As for radial gap, the gap is cylindrical and thus forcing the flow channel to be perpendicular to the flow path inside the valve. As a result, using external coil is preferable for radial gap as the electromagnetic coil is wrapped on the spool outside of the fluid flow making the direction of magnetic field from external coil is parallel to the flow path inside the control valve. As for the calculation of pressure drop for radial gap, it uses the same as Eq. (1), where the  $\Delta P_{viscous}$  and  $\Delta P_{yield}$  for radial gap are presented as (Wang et al. 2009):

$$\Delta P_{viscous} = \frac{6\eta Q}{\pi d^3 R} \ln \frac{R_1}{R_0} \quad (4)$$

$$\Delta P_{yield} = \frac{c \tau(b)}{d} (R_1 - R_0) \quad (5)$$

where  $R_1$  and  $R_0$  are the radial length from input to output of the flow channel.

Whilst the performance of the control valve is determined by its capability of manipulating pressure drop during damper's working condition, there are two ways to increase the pressure drop in the effective MR area within the valve. One of the ways is by increasing the effective area, where this can be achieved by increasing the flow path within the valve (Imaduddin et al. 2012). Since increasing the valve dimension is not preferable due to other factors that might affecting the valve performance such as weight, power consumption and less compact design, one of the options available is to extend flow path inside a smaller valve by twisting the flow path within the valve (Imaduddin et al. 2012). This concept helps to increase the effective area within the valve by alternating the annular and radial gap within the valve, thus increasing the effective area in the valve where in return increased the yield stress produced by the control valve, without having to increased neither the valve dimension nor its power consumption. The disadvantages by using this method to increase the effective area in the valve are increasing viscous resistance due to increase in length and narrowed in gap of the flow path that may cause some loss in yield stress and complexity of fabricating the flow path inside the valve due to the need to twist the flow path.

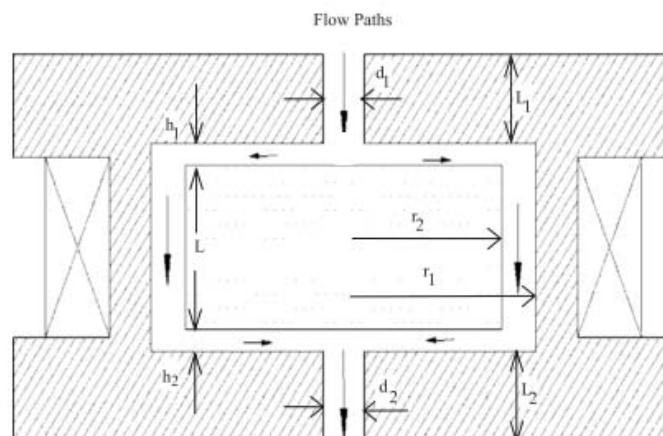

Fig. 3 MR valve by Gordaninejad in 2010 (Gordaninejad et al. 2010)

Another one way is to increase the number of magnetic flux into the effective area. As the MR fluid performs up to an optimum level of flux density based on the fluid properties, increasing the magnetic flux density is not a better choice. However, by weaving the magnetic flux into the effective area inside the valve, the effective area will be increased and this concept has been proven from a previous work, where it is dubbed as serpentine flux path (Senkal and Gurocak 2010). Serpentine flux path can be achieved by alternating the magnetic and nonmagnetic material inside the valve, thus weaving and guiding as much of the magnetic flux as possible into the effective area (Senkal and Gurocak 2010). Similar to twisting the flow path, this method twist the magnetic flux path into the effective area, however the flow path does not have to be increased and thus eliminates the disadvantages of increasing the flow path inside the valve. On the other hand, by using serpentine flux path method the loss of magnetic flux is evident, and even though the flux density can be increased by increasing current or number of turns inside the magnetic coil, this can lead to increasing heat inside the valve in addition of more power consumed for the valve. It is noted that serpentine flux path has only been applied to application of MR brake, and none of the previous work involved with application of serpentine flux path into control valve of an MR damper (Senkal and Gurocak 2010).

### 3. DESIGN OF VALVE WITH SERPENTINE FLUX PATH METHOD

A study by Gordaninejad et. al 2010 reported a 450 psi or about 3.1 bar for MR valve with annular fluid resistance gap and 700 psi (4.826 bar) for MR valve with modular disk type in single stage (Fig. 3) (Gordaninejad et al. 2010). The design of valve in the works of Gordaninejad et al. 2010 has been used as a basis for valve design by first replicating the valve so that similar result can be achieved, then improvement of the valve design by applying the serpentine flux path into the valve design.

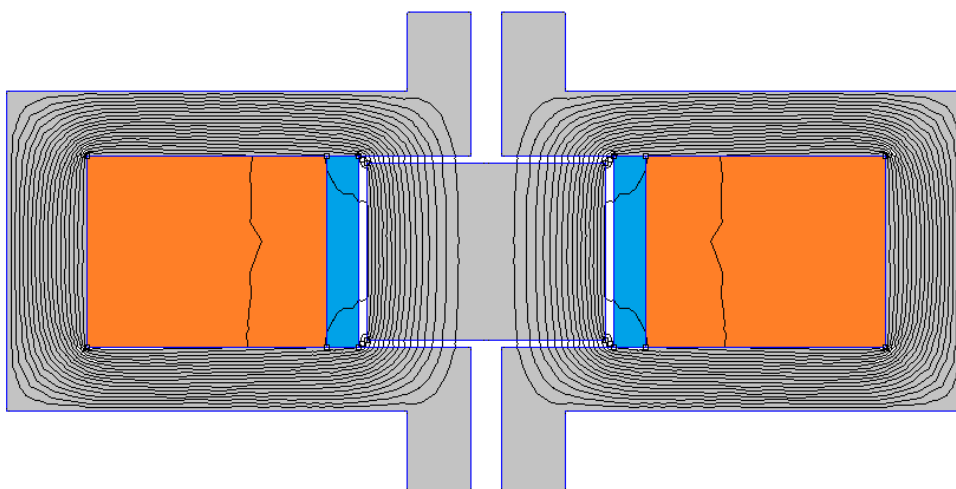

Fig. 4 Radial gap received more magnetic flux than annular gap in Gordaninejad's valve

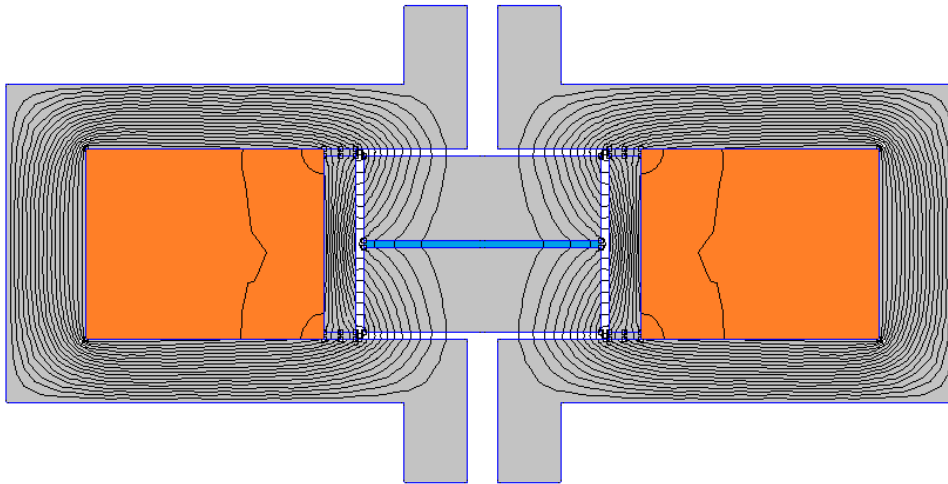

Fig. 5 One of initial ideas for valve design with serpentine flux path

One major problem with this valve design is that it only focused on radial gap rather than the annular gap as the valve design uses external coil, therefore the annular gap is not much being used here (Fig. 4). To maximize the effective area within the valve, this annular gap should be utilized and one of the ways is by serpentine flux path, where the magnetic flux can be weaved into the annular gap by manipulating the material selection of magnetic and non-magnetic to be arranged inside the valve (Fig. 5). By doing this, the effective area for MR effect in the valve is increased and thus increasing the yield stress within the bypass device to accommodate larger force within smaller dimension of valve.

The value of magnetic flux density in the valve can be determined by using Finite Element Method Magnetics (FEMM) simulation software, where the 2-D sketch of the valve is put into the software before the magnetic flux density can be monitored and determined (Fig. 5). Within the software the valve dimension, materials selection and configuration and coil configuration such as wire type and number of turns can be done so that valve design can be adjusted and configured quickly to get the maximum value of flux density in the effective area. The value of flux density is also used in calculating the yield stress within MR valve, where the calculation is based on the field-dependant yield stress formula, then applied in the calculation of pressure drop for annular and radial gap found in Eqs. (1)-(5).

The design in the discussed in this paper will be using the serpentine flux path method described by Senkal and Gurocak 2010 works, where the magnetic flux will be weaned into the fluid path in the valve as much as possible by alternating the non-magnetic and magnetic materials so that the magnetic flux will be forced to go into the annular gap in the valve, thus increasing the effective region within the valve. It will also be using external coil for its coil configuration, where this configuration is usually used for radial gap, but it will assume the annular gap as well since the magnetic flux is weaved into the annular gap of the valve.



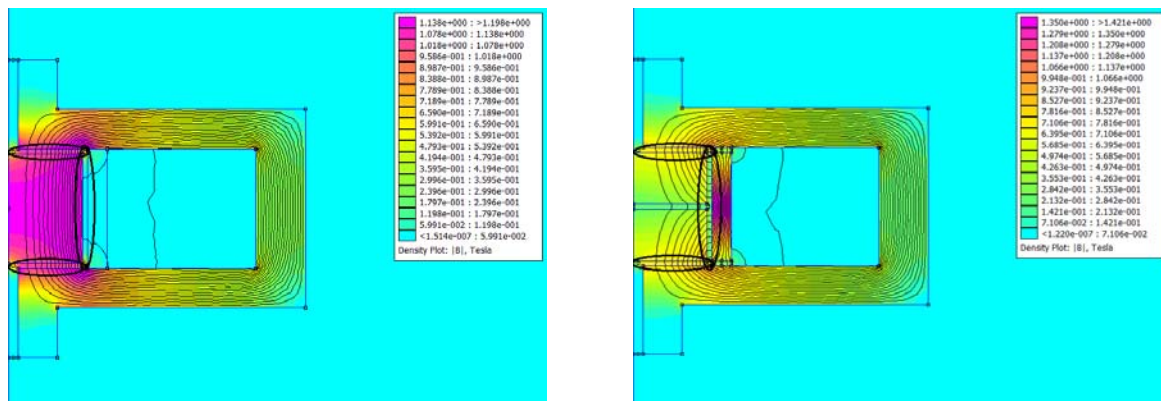

Fig. 6 FEMM Simulation between normal valve and serpentine-flux valve. Black ovals denote the three regions within the valves

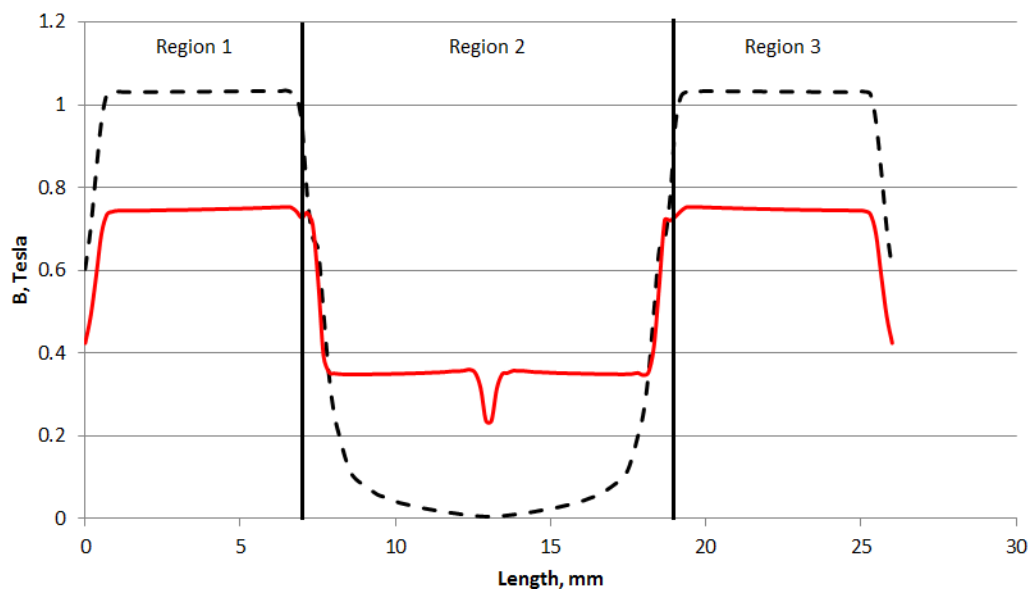

Fig. 7 Graph of magnetic flux density along the effective regions, black-dotted line represents normal valve while red-solid line represents serpentine-flux valve

## 4. RESULTS AND DISCUSSIONS

### 4.1 FEMM Simulation result

The simulation is done on normal valve found from Gordaninejad's study and the serpentine-flux valve. To make a fair comparison of performances between normal valve and serpentine-flux valve, the dimension of both valves are made same so that the length of effective regions and the number of turns for coils inside both valves can be made similar to each other. This means, the dimension in Gordaninejad's valve is

altered to suit the simulation and study (Gordaninejad et al. 2010). Fig. 6 shows the FEMM simulation done for both normal valve and valve with serpentine flux path, where the effective region in the valve is divided into three zones for average value of magnetic field strength. Data from the simulation made are presented in the graphs of magnetic field strength in those three zones for normal valve and valve with serpentine flux path, where they are shown in Fig. 7.

#### 4.2 Calculation of pressure drop in the valve

The average B value (magnetic field strength) obtained from FEMM simulation in three zones of effective regions of both normal valve from Gordaninejad's study and the valve with serpentine flux path are used in calculating field-dependent yield stress, where it is different for each of the MR fluid used. As for the study in this paper, MR fluid used is the MRF-132DG from Lord Corporation. The formula for field-dependent yield stress for MRF-132DG as found in literature is as follows (Nguyen et al. 2007):

$$\tau(B) = 52.962B^4 - 176.51B^3 + 158.79B^2 + 13.708B + 0.1442 \quad (6)$$

The field-dependent yield stress formula in Eq. (6) is then used in calculating  $\Delta P_{\text{yield}}$  for both annular and radial gap as found in Eq. (3) and Eq. (5). The pressure drop calculation for  $\Delta P_{\text{viscous}}$ ,  $\Delta P_{\text{yield}}$  and total pressure drop  $\Delta P_{\text{valve}}$  for three zones in the normal and serpentine-flux valve are presented in Table 1.

Table 1 Parameters and calculation for pressure drop

Valve	Normal valve			Serpentine-flux valve		
Regions	Region 1	Region 2	Region 3	Region 1	Region 2	Region 3
$\eta$ for MRF 132-DG (Pa·s)	0.112					
Q (ml/s)	10					
c	2					
d (mm)	0.5					
L (mm)	-	11.5	-	-	11.5	-
R (mm)	-	7.5	-	-	7.5	-
R <sub>1</sub> (mm)	7.5	-	7.5	7.5	-	7.5
R <sub>0</sub> (mm)	1	-	1	1	-	1
Avg. magnetic flux density (Tesla)	1.008	0.116	1.001	0.730	0.368	0.730
$\Delta P_{\text{viscous}}$ (bar)	0.345	0.262	0.345	0.345	0.262	0.345
$\Delta P_{\text{yield}}$ (bar)	12.767	1.657	12.767	10.698	8.707	10.701
$\Delta P_{\text{valve}}$ (bar)	13.112	1.919	13.111	11.043	8.969	11.046
Total pressure drop (bar)	28.143			30.058		

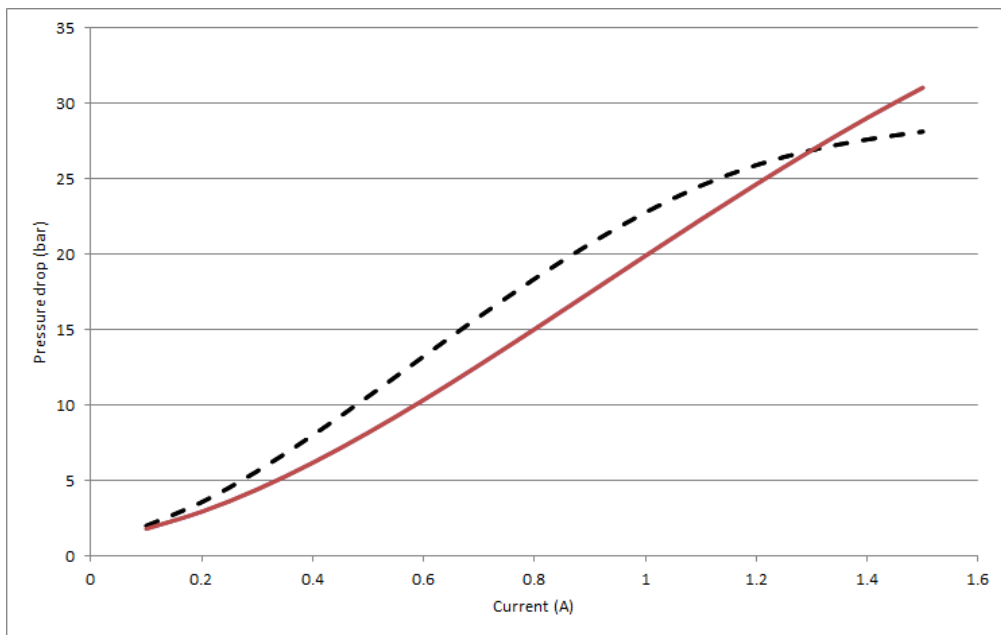

Fig. 8 Graph of pressure drop for normal valve

#### 4.3 Discussions

It can be seen from Table 1 that the pressure drop from serpentine flux valve is higher than the normal valve, using the maximum allowable current of 1.5A on AWG20 coil wire. However, when the currents are varied from 0.1 to 1.5A and plotted versus pressure drop on the graph, the pressure drop for valve with serpentine flux is lower than normal valve until the current of 1.3A, where the pressure drop is then increasing rapidly over the normal valve (Fig. 8). This might be due to the distribution of magnetic flux into the annular gap, where the magnetic flux intensity is decreased in the effective area, but distributed almost evenly in the annular and radial gaps. If seen from the graph of the total of average magnetic flux density in both valves, the magnetic flux density for normal valve is always higher than in serpentine-flux valve. Therefore, it can be said from the graph that with the same average value of Tesla, the serpentine valve achieved higher pressure drop than the normal valve.

## 5. CONCLUSIONS

Valve with serpentine flux path has been proposed in this study. With the design of the valve, several things can be achieved, such as:

- Higher pressure drop than normal valve when average magnetic flux density in the effective area is the same, providing both valves using the same dimension and same type of wire.
- With higher pressure drop achieved in the serpentine-flux valve, higher damping force could also be achieved.

- Higher MR effective region inside the valve due to the weaving of magnetic flux into the fluid path

## REFERENCES

- Ahmadian, M., Song, X.B. and Sandu, C. (2005), "Designing an adaptive semiactive magneto rheological seat suspension for heavy truck applications." *Smart Structures and Materials 2005: Damping and Isolation*, **5760**, 247–255.
- Blake, J, and Gurocak, H.B. (2009), "Haptic glove with MR brakes for virtual reality." *IEEE-Asme Transactions on Mechatronics* 14(5): 606–615.
- Carlson, J David, and Mark R Jolly. 2000. "MR fluid, foam and elastomer devices." *Mechatronics*, **10**(4-5), 555–569.
- Carlson, J.D., Matthis, W. and Toscano, J.R. (2001), "Smart prosthetics based on magnetorheological fluids." **4332**, 308–316.
- Carlson, J.D. and Chrzan, M.J. (1994), "Magnetorheological fluid dampers."
- Carlson, J.D. and Sproston, J.L. (2000), "Controllable fluids in 2000 - status of ER and MR fluid technology." *Actuator 2000 - 7th International Conference on New Actuators*, p. 126–130.
- Carmignani, C., Forte, P. and Rustighi, E. (2006), "Design of a novel magneto-rheological squeeze-film damper." *Smart Materials and Structures*, **15**(1), 164–170.
- Chen, C. and Liao, W.H. (2012), "A self-sensing magnetorheological damper with power generation." *Smart Materials & Structures*, **21**(2).
- Cho, S.W., Jung, H.J. and Lee, I.W. (2005), "Smart passive system based on magnetorheological damper." *Smart Materials & Structures*, **14**(4), 707–714.
- Choi, S.B., Hong, S.R., Cheong, C.C. and Park, Y.K. (1999), "Comparison of field-controlled characteristics between ER and MR clutches." *Journal of Intelligent Material Systems and Structures*, **10**(8), 615–619.
- Choi, Y.T. and Wereley, N.M. (2009), "Self-Powered Magnetorheological Dampers." *Journal of Vibration and Acoustics-Transactions of the Asme*, **131**(4).
- Dyke, S.J., Spencer, B.F., Sain, M.K. and Carlson, J.D. (1998), "An experimental study of MR dampers for seismic protection." *Smart Materials & Structures*, **7**(5), 693–703.
- Forte, P., Patern, M. and Rustighi, E. (2004), "A magnetorheological fluid damper for rotor applications." *The International Journal of Rotating Machinery*, **10**(3), 175–182.
- Ghaednia, H. and Ohadi, A. (2010), "Effect of thermal growth on vibration behavior of flexible rotor system mounted on MR squeeze film damper." *Proceedings of the Asme 10th Biennial Conference on Engineering Systems Design and Analysis, 2010*, **Vol 1**, 567–576.
- Goncalves, F.D. and Carlson, J.D. (2009), "An alternate operation mode for MR fluids—magnetic gradient pinch." *Journal of Physics: Conference Series* 149, 012050.
- Gordaninejad, F., Wang, X., Hitchcock, G., Bangrakulur, K. Ruan, S. and Siino, M. (2010), "Modular high-force seismic magneto-rheological fluid damper." *Journal of Structural Engineering-Asce*, **136**(2), 135–143.
- Huang, J., Chen, S. and Wang, P. (2011), "Analysis and design of a cylindrical MR valve." *New and Advanced Materials*, **Pts 1 and 2**, 197-198, 265–268.

Imaduddin, F., Mazlan, S.A. and Zamzuri, H. (2012), "Magnetorheological control valve with multiple annular and radial gaps." In *MJJS Symposium*, Kuala Lumpur, p. 1–4.

Ismail, I., Mazlan, S.A. and Olabi, A.G. (2010), "Magnetic circuit simulation for magnetorheological (MR) fluids testing rig in squeeze mode." *Advanced Materials Research*, **123-125**, 991–994.

Jolly, M.R., Carlson, J.D. and Munoz, B.C. (1996), "A model of the behaviour of magnetorheological materials." *Smart Materials & Structures*, **5**(5), 607–614.

Kordonsky, W.I., Gorodkin, S.P. and Demchuk, S.A. (1993), "Magnetorheological control of heat transfer." *International Journal of Heat and Mass Transfer*, **36**(11), 2783–2788.

Liu, B., Li, W.H., Kosasih, P.B. and Zhang, X.Z. (2006), "Development of an MR-brake-based haptic device." *Smart Materials & Structures*, **15**(6), 1960–1966.

Mazlan, S.A., Issa, A., Chowdhury, H.A. and Olabi, A.G. (2009), "Magnetic circuit design for the squeeze mode experiments on magnetorheological fluids." *Materials & Design*, **30**(6), 1985–1993.

Mazlan, S. A., Ismail, I., Zamzuri, H. and Abd Fatah, A.Y. (2011), "Compressive and tensile stresses of magnetorheological fluids in squeeze mode." *International Journal of Applied Electromagnetics and Mechanics*, **36**(4), 327–337.

Neelakantan, V.A. (2005), "Modeling and reduction of centrifuging in magnetorheological (MR) transmission clutches for automotive applications." *Journal of Intelligent Material Systems and Structures*, **16**(9), 703–711.

Nguyen, Q.H., Choi, S.B., Lee, Y.S. and Han.M.S. (2009), "An analytical method for optimal design of MR valve structures." *Smart Materials and Structures*, **18**(9): 095032.

Nguyen, Q.H., Han, Y.M., Choi, S.B. and Wereley, N.M. (2007), "Geometry optimization of MR valves constrained in a specific volume using the finite element method." *Smart Materials & Structures*, **16**(6), 2242–2252.

Poynor, J.C. (2001), "Innovative designs for magneto-rheological dampers." PhD. dissertation, Virginia Polytechnic Institute and State University, Virginia.

Rabinow, J. (1948). "The Magnetic Fluid Clutch." *AIEE Transactions*, **67**, 1308–1315.

Reichert, B.A. (1997), "Application of magnetorheological dampers for vehicle seat suspensions." Master dissertation, Virginia Polytechnic Institute and State University, Virginia.

Sahin, H., Gordaninejad, F., Wang, X. and Liu, Y. (2012), "Response time of magnetorheological fluids and magnetorheological valves under various flow conditions." *Journal of Intelligent Material Systems and Structures*, **23**(9), 949–957.

Şahin, İ., Morgül, Ö.K. and Engin, T. (2005), "Design and testing of a magnetorheological (MR) damper for tractor seat." *International Research/Expert Conference "Trends in the Development of Machinery and Associated Technology" TMT 2005*, Antalya, p. 1093–1096.

Sassi, S., Cherif, K., Mezghani, L., Thomas, M. and Kotrane, A. (2005), "An innovative magnetorheological damper for automotive suspension: from design to experimental characterization." *Smart Materials & Structures*, **14**(4), 811–822.

Senkal, D. and Gurocak, H. (2010), "Serpentine flux path for high torque MRF brakes in haptics applications." *Mechatronics*, **20**(3), 377–383.

Sgambelluri, N.R., Rizzo, R., Scilingo, E.P., Raugi, M. and Bicchi, A. (2006), "Free hand haptic interfaces based on magnetorheological fluids." *Symposium on Haptics*

*Interfaces for Virtual Environment and Teleoperator Systems 2006, Proceedings*, 367–371.

Sodeyama, H., Sunakoda, K., Fujitani, H. Soda, S., Iwata, N. and Hata, K. (2003), “Dynamic tests and simulation of magneto-rheological dampers.” *Computer-Aided Civil and Infrastructure Engineering*, **18**(1), 45–57.

Spencer, B.F., Dyke, S.J., Sain, M.K. and Carlson, J.D. (1996), “Phenomenological model of a magnetorheological damper.” *Journal of Engineering Mechanics-Asce*, **123**(3), 230–238.

Unsal, M. (2006), “Semi-active vibration control of a parallel platform mechanism using magnetorheological damping.” PhD. dissertation, University of Florida, Florida.

El Wahed, A.K. and Mcewan, C.A. (2011), “Design and performance evaluation of magnetorheological fluids under single and mixed modes.” *Journal of Intelligent Material Systems and Structures*, **22**(7): 631–643.

Wang, D.H., Ai, H.X. and Liao, W.H. (2009), “A magnetorheological valve with both annular and radial fluid flow resistance gaps.” *Smart Materials & Structures* **18**(11).

Wang, J., Feng, N., Meng, G. and Hahn, E.J. (2006), “Vibration control of rotor by squeeze film damper with magnetorheological fluid.” *Journal of Intelligent Material Systems and Structures*, **17**(4), 353–357.

Weiss, K.D., Carlson, J.D. and Nixon, D.A. (1994), “Viscoelastic properties of magneto- and electro-rheological fluids.” *Journal of Intelligent Material Systems and Structures*, **5**(6), 772–775.

Wereley, N.M., Cho, J.U., Choi, Y.T. and Choi, S.B. (2008), “Magnetorheological dampers in shear mode.” *Smart Materials and Structures*, **17**(1), 015022.

Yalcintas, M, and Dai, H.M. (1999), “Magnetorheological and electrorheological materials in adaptive structures and their performance comparison.” *Smart Materials & Structures*, **8**(5), 560–573.

Yang, G., Spencer, B.F., Carlson, J.D. and Sain, M.K. (2002), “Large-scale MR fluid dampers: modeling and dynamic performance considerations.” *Engineering Structures*, **24**(3), 309–323.

Zhou, W., Chew, C.M. and Hong, G.S. (2007), “Development of a compact double-disk magneto-rheological fluid brake.” *Robotica*, **25**, 493–500.

Zhu, X., Jing, X. and Cheng, L. (2012), “Magnetorheological fluid dampers: A review on structure design and analysis.” *Journal of Intelligent Material Systems and Structures*, **23**(8), 839–873.